

# CONTEST DESIGNS

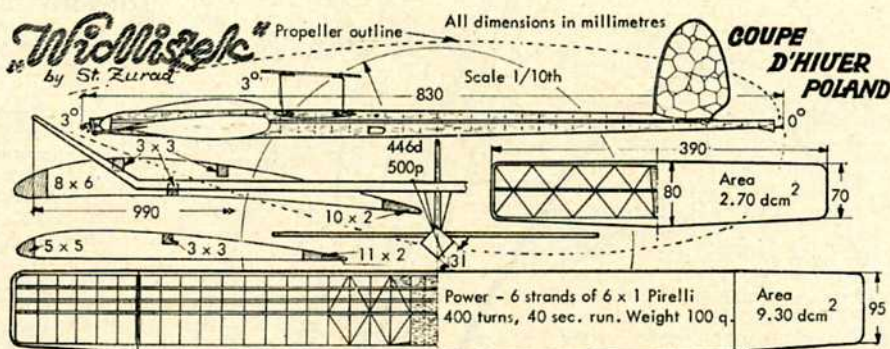

THE ACADEMY OF MODEL AERONAUTICS has a record category which permits models in the free flight F.A.I. classes to make continuous maximum flights for an accumulated time which naturally terminates when the model fails to make a flight of three minutes. During a record trials, Bob Cherny of Sacramento, California, managed a most creditable total of 41 minutes 46 seconds using **Orbiteer** — a development with elliptical surfaces of the model which was flown by Doug Galbreath in the 1963 World Championships. A photograph of Bob launching this model, together with initial comment was published in "Heard at the Hangar Doors" of June

this year. For the actual record flights the new Rev-Up 8 x 3 3/4 in. propeller was employed.

Winter Cup or Coupe d'Hiver rubber driven model events are gaining international popularity and this month we have a Polish design by Stanislaw Zurad with high pylon supported wing and created for relatively low power run. Known as **Widliszek**, (Mosquito) the model features a 2-blade folding prop and characteristic short motor extending to just behind the trailing edge of the wing. Winter Cup activities will soon be resuming throughout Europe and we hope once more to conduct our part in the annual Anglo-French challenge event again early in 1965. All British modellers interested in our postal event are invited to register their names and addresses at the Editorial Offices for the first new circular.

F. A. I. POWER  
U. S. RECORD 41 : 46

## ORBITEER

By R. Cherny & R. Gregory

SCALE 1 : 12

